

The RF Power Analyzer:

A lower-cost alternative to the spectrum analyzer for cell phone and RFIC power amplifier production test

Robert Green
Telecommunications Market Development Manager
Keithley Instruments

Today's RF power analyzers can automate many of the steps in testing cell phones and similar RF devices, saving users time and money.

THE choice between laboratory and production test equipment is the choice between general-purpose instruments and dedicated instruments. A spectrum analyzer is a very flexible piece of equipment that can be used for many things, but that flexibility comes at the price of low speed, complicated setups, and high equipment costs. An RF power analyzer is dedicated to production testing of cell phones, RFIC power amplifiers, and similar devices. It can perform an array of tests that previously required several instruments, and do them faster and at lower cost—but it's not designed for general laboratory use. This article will explore the differences between RF power analyzers and spectrum analyzers and make the point that, for the jobs for which it is suited, an RF power analyzer is a more attractive choice than a spectrum analyzer.

Descriptions of the Two Classes of Instruments

A spectrum analyzer does swept-frequency measurements on RF signals and displays results on a screen. In many cases, it can also store screen images in .gif or similar formats and sometimes provide output in spreadsheet form. It has a very broad frequency range. For example, one spectrum analyzer suitable for cell phone test applications covers 3Hz to 6.7GHz. This and many other things make

the spectrum analyzer ideal for development work and few instruments can approach it in its areas of strength.

An RF power analyzer (*Figure 1*) is a much more specialized instrument. It measures RF power and frequency over defined bandwidths and frequency ranges. It doesn't cover the hertz-to-gigahertz frequency range of a spectrum analyzer, and it doesn't do the complex modulation analysis of a vector signal analyzer. Instead of a sweeping oscillator, it uses multiple oscillators for the multiple narrow bands it measures. This increases measurement speed, because frequency changes are very quick. Intended for production line use, it has no built-in graphical display, but reports its results directly to a computer. It is, first and last, a production test instrument. It also costs considerably less than a spectrum analyzer, and is much faster to set up for a particular test.

Ease of Setup

A spectrum analyzer, being a very versatile instrument, is correspondingly laborious to set up. An RF power analyzer, because it is intended for certain specific tests, has the parameters for those tests pre-programmed. It can be set up from the front panel using a menu, or by computer via an IEEE-488 link. It can take just five GPIB commands to measure and transfer five readings—carrier channel power, upper adjacent channel power, lower adjacent channel power, upper alternate channel power, and lower alternate channel power—to the external PC controller. A spectrum analyzer may take from two to eight times as many commands to do the same job.



Figure 1. The Keithley Model 2800 RF Power Analyzer is intended for production testing of cell phones and RFIC power amplifiers.

Speed

An RF power analyzer is from four to ten times faster for cell phone production tests than a spectrum analyzer. For example, it can make a 1.23MHz bandwidth cdmaOne primary power measurement and transfer the measurement to a computer in 6ms. It can make a 3.84MHz bandwidth primary channel measurement in 10ms, and can make power measurements on consecutive 577 μ s GSM pulses occurring every 4.6ms. It can make a cdmaOne primary power measurement, an upper adjacent power measurement, lower adjacent power measurement, upper alternate power, and lower alternate power—a total of five measurements (*Figure 2*)—in only 23ms (including PC command time and data transfer to the PC time). A GSM primary power measurement and two spurious power measurements take only 14ms.

Physical Size

An RF power analyzer is a compact device that often takes up just three and one-half inches of rack space. Top-of-the line spectrum analyzers run from seven to nine inches high; two RF power analyzers could be put in the same rack space.

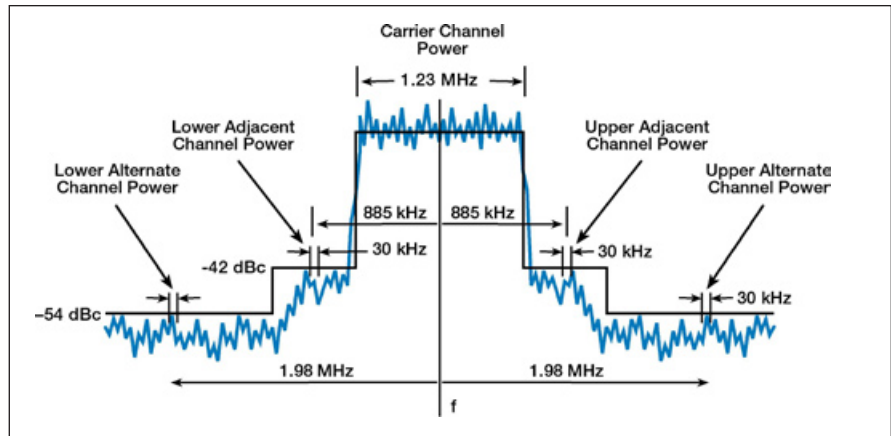

Figure 2. Power spectral density plot of a cdmaOne transmission, showing limits on adjacent-channel and alternate-channel power.

Cost

A representative top-of-the-line spectrum analyzer with the features necessary for cell phone testing costs \$43,000+, while a communications analyzer can run from \$30,000 to \$80,000. An RF power analyzer is a fraction of that, at about \$16,000.

Conclusion

A spectrum analyzer is an excellent choice for development work on cell phones and RFIC power amplifiers, but using it for

production testing is like cracking walnuts with a sledgehammer. An RF power analyzer can handle the job faster and more easily, and at a fraction of the cost. KEITHLEY

About the Author

Robert Green is Telecommunications Market Development Manager at Keithley Instruments, Inc. in Cleveland, Ohio. He can be contacted by e-mail at rgreen@keithley.com or by telephone at 440-248-0400.

Specifications are subject to change without notice.

All Keithley trademarks and trade names are the property of Keithley Instruments, Inc. All other trademarks and trade names are the property of their respective companies.

KEITHLEY

Keithley Instruments, Inc.

28775 Aurora Road • Cleveland, Ohio 44139 • 440-248-0400 • Fax: 440-248-6168
1-888-KEITHLEY (534-8453) • www.keithley.com

© Copyright 2004 Keithley Instruments, Inc.
Printed in the U.S.A.

No. 2523
0304